

INFINITY 60 ROTARY SCREW AIR COMPRESSOR



INFINITY 60

BIG ENOUGH TO HANDLE THE TOUGHEST JOBS...

SMALL ENOUGH TO BE VERSATILE AND LIGHT WEIGHT!

BOSS®

*The
Difference is
Revolutionary™*

INFINITY 60 HYDRAULIC ROTARY SCREW SERIES

A COMPACT, STRATEGICALLY DESIGNED SYSTEM, THE INFINITY 60™ INTEGRATES ALL MAJOR COMPONENTS ON A SINGLE FRAME, WHICH IS ENCLOSED IN A TOUGH, WEATHER-RESISTANT CANOPY.

ENHANCED SAFETY FEATURES

The INFINITY 60™ offers a number of standard safety features designed to protect your most valuable resource - your operating crew. Minimum pressure valves, a compressor high-temperature and high-pressure safety system, an automatic blow-down device, high pressure relief valve, and clearly displayed warning and information decals help safeguard your workforce. A hydraulic manifold block with relief and solenoid valves sends excess flow back to the tank, eliminating overspeeding and potential damage to the compressor unit and coolers.

HIGH OUTPUT, GREATER PERFORMANCE

The INFINITY 60™'s rotary screw design guarantees continuous output of up to 60 CFM at 150 PSI. High output at relatively low GPM translates into the most efficient, quiet, and reliable system in its class, designed to handle virtually any underground application.

EASE OF MAINTENANCE AND SERVICE

With built-in access ports and a hinged canopy panel, virtually all components are accessible for maintenance and service. Instrumentation, which clearly displays pressure, temperature, and hour meters, also includes a remote oil level indicator light, a service indicator light for air filter replacement, and a high-temperature and high-pressure reset button. Other features, including a washable, reusable compressor oil filter and a self-contained separator element with a spin-on housing, reduce the time and costs associated with routine maintenance.

COMPREHENSIVE SYSTEM

With the INFINITY 60™, every major component - even those that are often considered "add-ons" - are included in this single, compact unit. These include the air end, oil receiver tank, oil filter, inlet valve, coalescer filter, thermal valve, air inlet filter, air pressure regulator, and a combination hydraulic cooler/air after-cooler/compressor oil cooler system.

Delivery @ 150 PSI	45 CFM	60 CFM
Hydraulic Fluid Required @ 2470 PSI Approx.	10 GPM	13 GPM
Oil Fluid Sump Capacity (System)	3/4 gallon (1 gallon)	3/4 gallon (1 gallon)
Electric System	12 VDC	12 VDC
Approximate Dry Weight	300 lbs.	300 lbs.

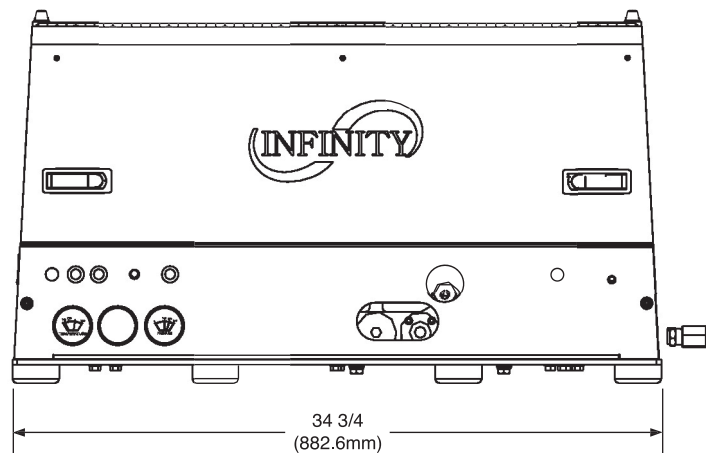
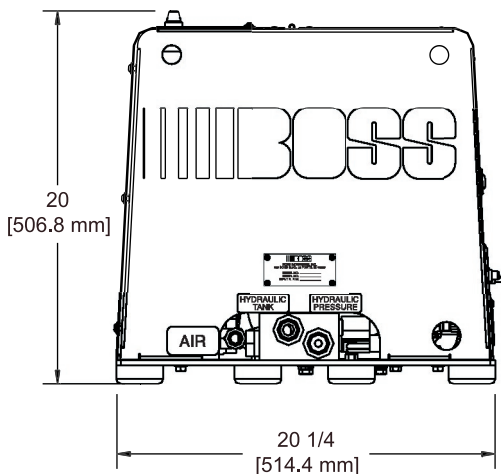

BOSS *The Difference is Revolutionary™*

DISTRIBUTED BY:

BOSS INDUSTRIES, INC.